

WARREN RUPP®

Quality System
ISO9001 Certified

Environmental
Management System
ISO14001 Certified

IDEX
FLUID & METERING



SANDPIPER®
A WARREN RUPP PUMP BRAND

Heavy Duty Flap Valve
HDF2-A Type 5
Air-Operated
Double Diaphragm Pump

ENGINEERING, PERFORMANCE
& CONSTRUCTION DATA



I M2 c T5
II 2GD T5

INTAKE/DISCHARGE PIPE SIZE 2" NPT (F) (50mm)	CAPACITY 0 to 140 gallons per minute (0 to 530 liters per minute)	AIR VALVE No-lube, no-stall design	SOLIDS-HANDLING Up to 2" (50mm)	HEADS UP TO 125 psi or 289 ft. of water (8.8 Kg/cm ² or 88 meters)
---	---	--	------------------------------------	---

SANDPIPER® pumps are designed to be powered **only** by compressed air.

MODEL HDF2-A
PERFORMANCE CURVE

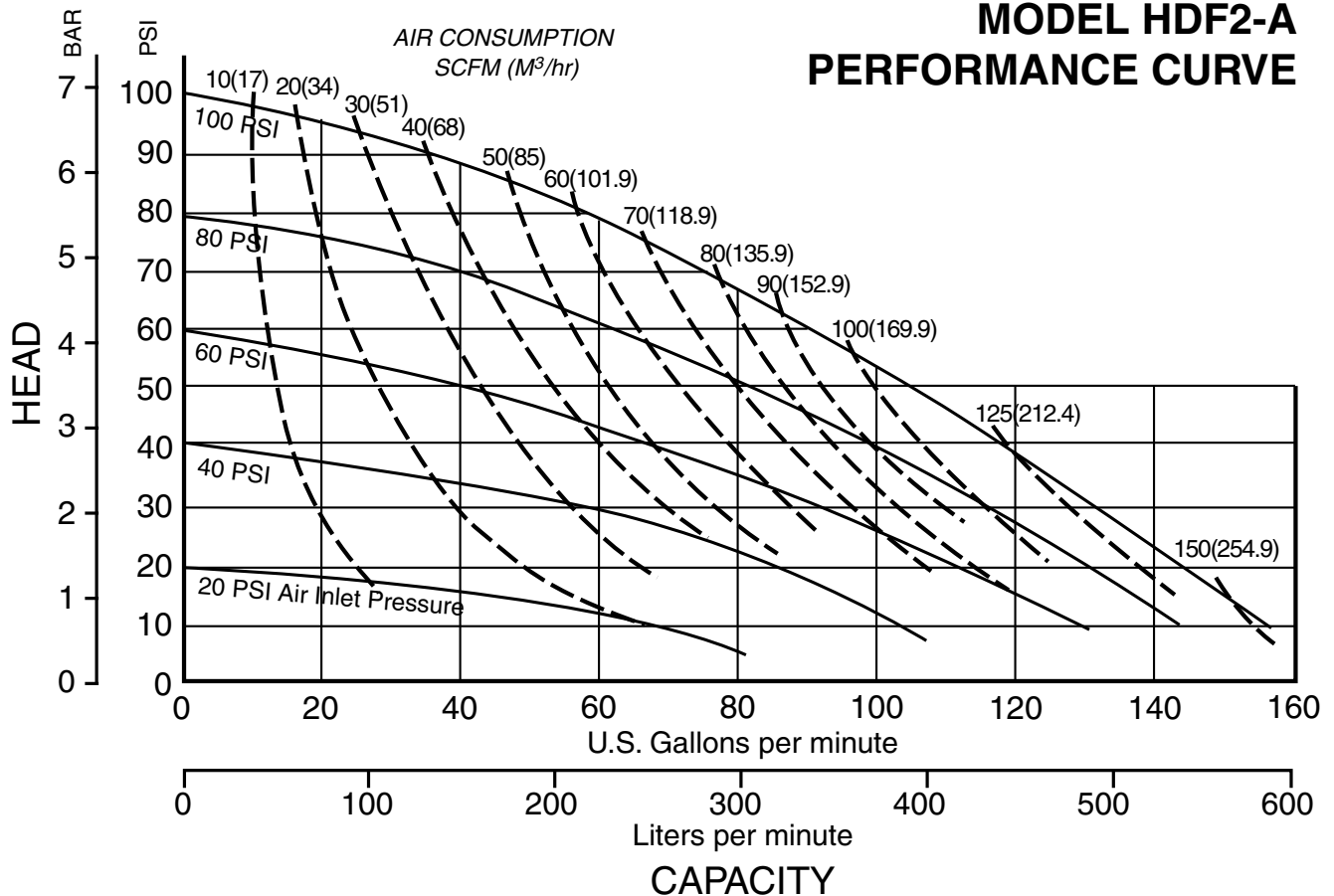

Meanings of Abbreviations:

A = Compressed Fibre	DC = Die Cast	PS = Plated Steel	SS/I = Stainless Steel seat with EPDM O-Ring
AL = Aluminum	H = Hytrel®	S = Santoprene®	T = PTFE
B = Nitrile	I = EPDM	SS = Stainless Steel	U = Urethane
CI = Cast Iron	N = Neoprene	V = FKM (Fluorocarbon)	F = FDA Accepted White Nitrile

Most types available in dual port design. See price book or consult factory for details.
 Hytrel is a registered tradename of E.I. du Pont. Santoprene is a registered tradename of Monsanto Corp.

Materials	Operating Temperatures		
	Maximum*	Minimum*	Optimum**
Nitrile/FDA White Nitrile General purpose, oil-resistant. Shows good solvent, oil, water and hydraulic fluid resistance. Should not be used with highly polar solvents like acetone and MEK, ozone, chlorinated hydrocarbons and nitro hydrocarbons.	190°F 88°C	-10°F -23°C	50°F to 140°F 10°C to 60°C
EPDM Shows very good water and chemical resistance. Has poor resistance to oil and solvents, but is fair in ketones and alcohols.	212°F 100°C	-10°F -23°C	50°F to 212°F 10°C to 100°C
NEOPRENE All purpose. Resistant to vegetable oils. Generally not affected by moderate chemicals, fats, greases and many oils and solvents. Generally attacked by strong oxidizing acids, ketones, esters, nitro hydrocarbons and chlorinated aromatic hydrocarbons.	170°F 77°C	-35°F -37°C	50°F to 130°F 10°C to 54°C
HYTREL® Good on acids, bases, amines and glycols at room temperature.	190°F 88°C	-10°F -23°C	50°F to 140°F 10°C to 60°C
FKM (Fluorocarbon) shows good resistance to a wide range of oils and solvents; especially all aliphatic, aromatic and halogenated hydrocarbons, acids, animal and vegetable oils. Hot water or hot aqueous solutions (over 70°F) will attack FKM.	212°F 100°C	32°F 0°C	75°F to 212°F 24°C to 100°C
Urethane Shows good resistance to abrasives. Has poor resistance to most solvents and oils.	150°F 66°C	+32°F 0°C	50° to 110°F 10°C to 43°C
Santoprene® Injection molded thermoplastic elastomer with no fabric layer. Long mechanical flex life. Excellent abrasion resistance.	212°F 100°C	-10°F -23°C	50° to 212°F 10°C to 100°C

†**CF-8M Stainless Steel** equal to or exceeding ASTM specification A743 for corrosion resistant iron chromium, iron chromium nickel, and nickel based alloy castings for general applications. Commonly referred to as 316 Stainless Steel in the pump industry.

For specific applications, always consult "Chemical Resistance Chart" Technical Bulletin

* Definite reduction in service life.

** Minimal reduction in service life at ends of range.

MATERIALS OF CONSTRUCTION

HDF2-A Type 5	Manifold Elbow	Outer Chamber	Inner Chamber	Outer Diaphragm Plate	Inner Diaphragm Plate	Intermediate Housing	Diaphragm Rod	Valve Seat	Hard-ware	Diaphragm	Flap Valve Material	Seat Gasket	Sealing Rings	Shipping Wt.(lbs)
DA-5-A	AL380DC	AL380DC	AL 380DC	PS	PS	356-T6AL	416SS	316SS	PS	N	U	A	N	86
DB-5-A	AL380DC	AL380DC	AL 380DC	PS	PS	356-T6AL	416SS	316SS	PS	B	B	A	B	86
DV-5-A	AL380DC	AL380DC	AL 380DC	PS	PS	356-T6AL	416SS	316SS	PS	V	V	A	V	86
DN-5-A	AL380DC	AL380DC	AL 380DC	PS	PS	356-T6AL	416SS	316SS	PS	N	N	A	N	86
DI-5-A	AL380DC	AL380DC	AL 380DC	PS	PS	356-T6AL	416SS	316SS	PS	I	I	A	I	86
DP-5-A	AL380DC	AL380DC	AL 380DC	PS	PS	356-T6AL	416SS	316SS/I	PS	S	S	N/A	I	86
DR-5-A	AL380DC	AL380DC	AL 380DC	PS	PS	356-T6AL	416SS	316SS	PS	H	H	A	N	86
DA-5-I	CI	CI	AL 380DC	PS	PS	356-T6AL	416SS	316SS	PS	N	U	A	N	133
DB-5-I	CI	CI	AL 380DC	PS	PS	356-T6AL	416SS	316SS	PS	B	B	A	B	133
DV-5-I	CI	CI	AL 380DC	PS	PS	356-T6AL	416SS	316SS	PS	V	V	A	V	133
DN-5-I	CI	CI	AL 380DC	PS	PS	356-T6AL	416SS	316SS	PS	N	N	A	N	133
DI-5-I	CI	CI	AL 380DC	PS	PS	356-T6AL	416SS	316SS	PS	I	I	A	I	133
DR-5-I	CI	CI	AL 380DC	PS	PS	356-T6AL	416SS	316SS	PS	H	H	A	N	133
DP-5-I	CI	CI	AL 380DC	PS	PS	356-T6AL	416SS	316SS/I	PS	S	S	N/A	I	133
DA-5-II	CI	CI	CI	PS	PS	CI	416SS	316SS	PS	N	U	A	N	168
DB-5-II	CI	CI	CI	PS	PS	CI	416SS	316SS	PS	B	B	A	B	168
DV-5-II	CI	CI	CI	PS	PS	CI	416SS	316SS	PS	V	V	A	V	168
DN-5-II	CI	CI	CI	PS	PS	CI	416SS	316SS	PS	N	N	A	N	168
DI-5-II	CI	CI	CI	PS	PS	CI	416SS	316SS	PS	I	I	A	I	168
DP-5-II	CI	CI	CI	PS	PS	CI	416SS	316SS/I	PS	S	S	N/A	I	168
DA-5-S	†SS	†SS	AL 380DC	†SS	PS	356-T6AL	416SS	316SS	PS	N	U	A	N	133
DB-5-S	†SS	†SS	AL 380DC	†SS	PS	356-T6AL	416SS	316SS	PS	B	B	A	B	133
DF-5-S	†SS	†SS	AL 380DC	†SS	PS	356-T6AL	416SS	316SS	PS	F	F	F	F	133
DV-5-S	†SS	†SS	AL 380DC	†SS	PS	356-T6AL	416SS	316SS	PS	V	V	A	V	133
DN-5-S	†SS	†SS	AL 380DC	†SS	PS	356-T6AL	416SS	316SS	PS	N	N	A	N	133
DI-5-S	†SS	†SS	AL 380DC	†SS	PS	356-T6AL	416SS	316SS	PS	I	I	A	I	133
DP-5-S	†SS	†SS	AL 380DC	†SS	PS	356-T6AL	416SS	316SS/I	PS	S	S	N/A	I	133
DR-5-S	†SS	†SS	AL 380DC	†SS	PS	356-T6AL	416SS	316SS	PS	H	H	A	N	133
DA-5-SI	†SS	†SS	CI	†SS	PS	CI	416SS	316SS	PS	N	U	A	N	168
DB-5-SI	†SS	†SS	CI	†SS	PS	CI	416SS	316SS	PS	B	B	A	B	168
DV-5-SI	†SS	†SS	CI	†SS	PS	CI	416SS	316SS	PS	V	V	A	V	168
DN-5-SI	†SS	†SS	CI	†SS	PS	CI	416SS	316SS	PS	N	N	A	N	168
DI-5-SI	†SS	†SS	CI	†SS	PS	CI	416SS	316SS	PS	I	I	A	I	168
DP-5-SI	†SS	†SS	CI	†SS	PS	CI	416SS	316SS/I	PS	S	S	N/A	I	168

† See CF-8M Materials information above.

HDF2-A

This pump also available in dual port design.
See price book or consult factory for details.

Dimensions are $\pm 1/8"$
Figures in parenthesis = millimeters

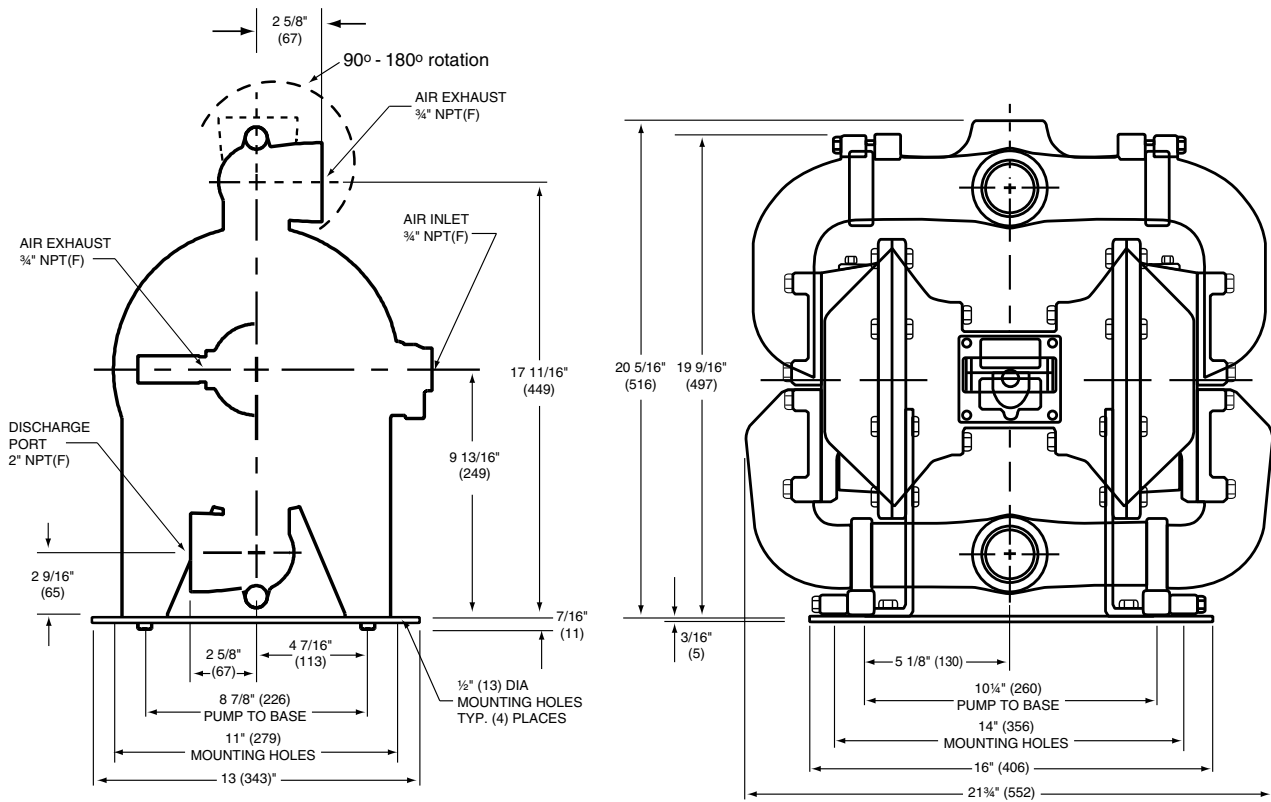

2" NPT(F) Suction and Discharge • $3/4"$ NPT(F) Air Inlet Port • $3/4"$ NPT(F) Air Exhaust Port (not shown)